

REVISIONS				
REV	DESCRIPTION OF REVISION	ECN No.	DATE	APPROVED
A	INITIAL RELEASE	—	01/08/12	M. Dong

## TECHNICAL DATA

### Electrical

Impedance	50 Ω
Frequency range	0~18 GHz
VSWR	1.15:1
Contact resistance	
-centre contact	≤1mΩ
-outer contact	≤0.2mΩ
Insulation resistance	≥5000MΩ

### Mechanical & Environmental

Durability (matings)	>500
Temperature range	-55 °C ~ +165 °C
RoHS Compliant	Yes

### Material & Finish

Body	Stainless Steel (SU303), Passivated
Pin Contact	Beryllium Copper Alloy, Gold-plated
Insulator	PEI & PTFE

### Interface Standards

N	MIL-STD-348A
---	--------------

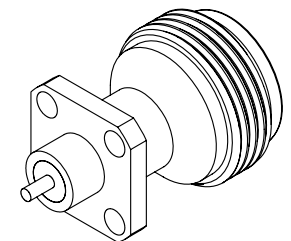
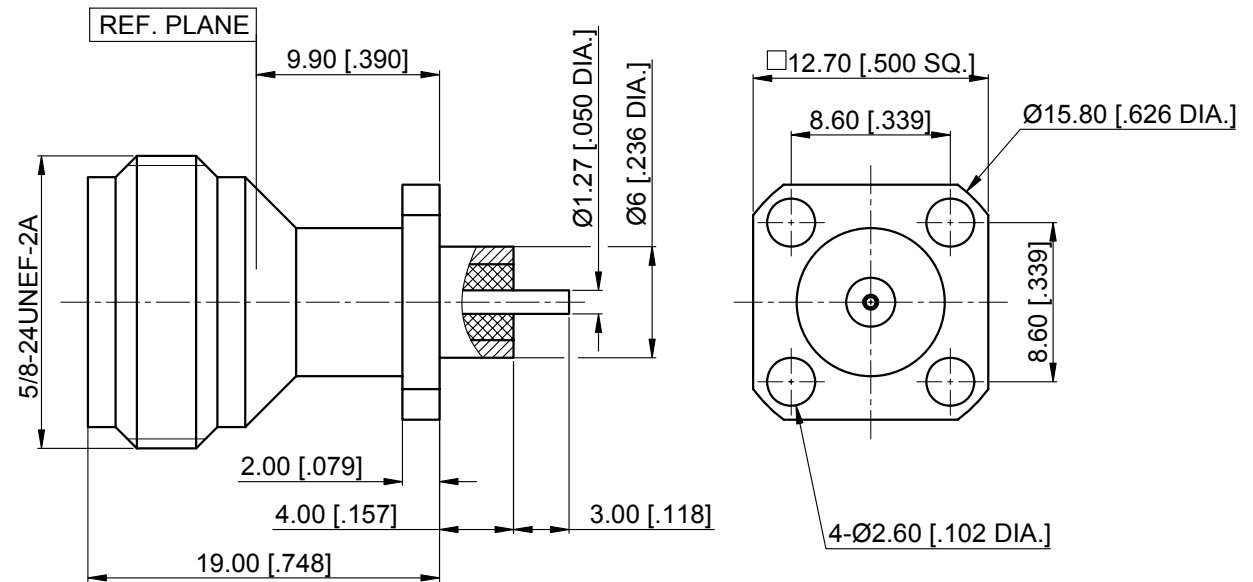

### NOTES:

- ALL SPECIFICATIONS ARE SUBJECT TO CHANGE WITHOUT NOTICE AT ANY TIME
- UNLESS OTHERWISE SPECIFIED ALL DIMENSIONS ARE NOMINAL.

DRAWN:	W. Shen	01/08/12
CHECKED:	K. Liu	01/08/12
APPROVED:	M. Dong	01/08/12
UNLESS OTHERWISE SPECIFIED, DIMENSIONS ARE IN MILLIMETERS [INCHES]. UNLESS OTHERWISE SPECIFIED DIMENSIONAL TOLERANCES ARE:		
	XX	±0.13 [.005"]
	X	±0.20 [.008"]
	X	±0.50 [.019"]
ANGULAR TOLERANCES ARE: ALL=±1°		

### TITLE:

N Straight Female,  
4 Hole Flange,  
Metal Through the Wall

DO NOT SCALE  
DRAWING

PROJECTION:

**CONNOR**<sup>®</sup>  
www.connor.com

PART No.:

C20214008

SIZE:  
A4

SCALE:  
2.5:1

SHEET:  
1/1

REV:  
A